

## **MIDI Controller Manual – Angelo Fraietta**

The MIDI Controller is a device used for converting control voltages to definable MIDI messages and visa versa. The device has thirty-two inputs (sixteen 10-bit 0 to +5 volt scalable control voltage and sixteen digital switch inputs), which can be used by a performer to generate MIDI control messages to one of two MIDI outputs -- depending upon the configuration of the device and the state of these inputs. The device also has four (can be upgraded up to eight) 10-bit scalable 0 to 10V analogue outputs, and eight 0 to 5V digital outputs. These outputs are controlled by inputting a MIDI control messages (say from a MIDI keyboard, sequencer, or other MIDI device), and if the controller is configured to respond to the message, the controller will alter the output voltage depending upon the message. This makes it possible to control up to sixteen low current (30 mA) analogue devices (like an analogue synthesizer, relays, or lighting controllers) using a MIDI keyboard, MIDI sequencer, or any other MIDI generating device. Additionally, the device has a merge feature that will merge incoming MIDI messages with those generated by the controller on MIDI output port 1. The MIDI controller is powered by a 12VAC 1 Amp power supply.

### **Control Voltage to MIDI conversion.**

The control voltage to MIDI conversion is separated into two sections: scalable voltage and digital switch, of which there is sixteen of each. Warning: Voltage inputs greater than 5V will generate spurious messages on other channels. Voltages greater than 15V may cause damage to the unit.

## **Scalable Voltage Input**

Each scalable voltage input operates from a voltage ranging from 0 to +5V and generates MIDI messages as configured. For example, consider the following configuration: voltage input one is configured to generate MIDI controller 12 messages on MIDI channel 1 on MIDI output port 1. Increasing the voltage from zero to five volts on voltage input 1 would cause the controller to generate MIDI controller 12 messages on MIDI channel 1 on MIDI output port 1 with a controller value ranging from 0 to 127. The value of the data 2 byte in the message is proportional to the voltage at the input.

Alternatively, consider the following configuration: voltage input 2 is configured to generate MIDI note on messages on MIDI channel 12 with a velocity value of 127 on MIDI output 2. Additionally, the channel is configured to invert the value. Increasing the voltage from 0 to +5V on voltage input 2 would cause the controller to generate MIDI note on messages on MIDI channel 12 with a note number ranging from 127 to 0 on MIDI output port 2, while the velocity remains at 127. In this case, the value of data byte 1 is inversely proportional to the voltage at the input.

Warning: Voltage inputs greater than 5V will generate spurious messages on other channels. Voltages greater than 15V may cause damage to the unit.

The unit can be configured to use ten-bit resolution in three different ways: using pitch bend, using two MIDI messages, or scaling the input voltage

## ***Pitch Bend***

If the channel is set up to use a Pitch Bend message, the MIDI message will produce a 10-bit value. The seven most significant bits will be transmitted in the second data byte, while the three least significant bits will be transmitted in the first data byte. Consider the configuration in Figure 1.

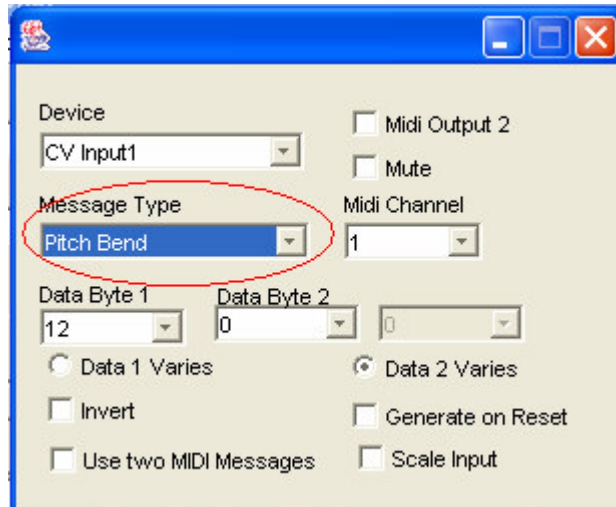
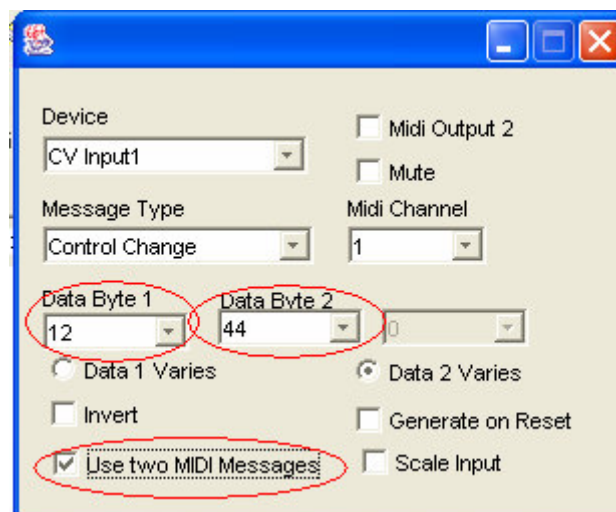

**Figure 1 Analogue In configured for Pitch Bend**

An input voltage of 5mV on the first CV input will generate a Pitch Bend message on channel 1 with data 1 being 1, and data 2 being zero.

### ***Using Two MIDI Messages***

The device can be configured to send two MIDI messages when the input voltage changes. The seven most significant bytes are transmitted in the first MIDI message in the second data byte, while the three least significant bits are transmitted in the second MIDI message. Consider the configuration shown in Figure 2.

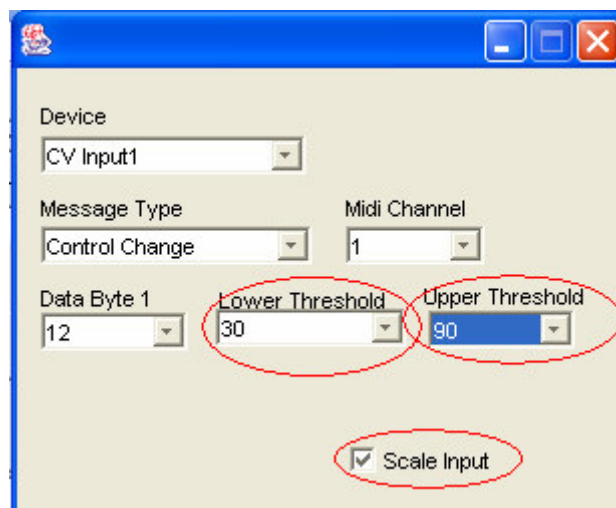

**Figure 2 Sending CV input value over two MIDI messages**

An input voltage of 5mV will cause a two MIDI controller messages to be generated on MIDI channel 1. The first message will be controller number 12 with a value of zero, while the second message will be controller 44 with a value of 1.

### ***Scaling Analogue Input***

The final method of using 10-bit resolution is through the use of the scaling mechanism. This can be particularly useful when the user is only interested in values that range between certain voltages. If a simple passive sensor—for example a force sensitive resistor—only produced voltages ranging from 1.17V to 3.51V, using a standard non-scaled value would produce MIDI messages with the CV representation ranging from 30 to 90. Additionally, the resolution of voltage changes would only be 7-bit, which means that a change would only be recognised for a change of 39mV. This means that there would be only 50 different possible values generated using that sensor. By using the scaling function, the device can be set to output values only between certain values, outputting a MIDI value ranging from 0 to 127. In this instance, the device can be set to monitor between 30 and 90. Given that the MIDI data byte only has seven bit resolution, The new resolution for this sensor would be approximately 18mV, which is twice what it was without scaling. The sensor would be configured as shown in Figure 3.



**Figure 3 Scaling CV Input**

Moving the sensor from minimum to maximum will produce a MIDI Controller message on channel 1 ranging from 0 to 127.

### **Digital Switch Input**

The digital switch input generates a MIDI message when the input is shorted to ground or a short is removed. Consider the following configuration: Digital switch input one is configured to generate MIDI controller 64 on MIDI channel 1. When the input is shorted to ground, the controller will generate MIDI controller 64 with a value of 127 on MIDI channel 1. The controller will generate the same message (with the exception that the controller value will be 0 instead of 127) when the short is removed. Data byte 2 contains a value of 127 for a short and 0 when the short removed. The inputs can be configured to invert the values or determine which data byte contains the state of the input, similar to the scalable voltage inputs.

Warning: Voltages greater than 5V on the Digital inputs may cause damage to the unit.

### **Control Voltage Outputs**

The control voltage outputs are divided into two sections: scalable analogue (0 to +10V) and digital (0 and +5V).

### **Scalable Voltage Output**

The scalable voltage output generates a voltage ranging from 0 to +10V depending upon the incoming MIDI message and the configuration. Consider the following configuration: scalable output 1 is configured to generate a voltage when the controller receives a MIDI control 1 message on MIDI channel 1 through its MIDI input. If a series of MIDI controller 1 messages on MIDI channel 1 with controller values ranging from 0 to 127 are received, the MIDI controller will generate a voltage ranging from 0 to +10V. The voltage generated is directly proportional to the MIDI data byte 2 value.

Alternatively, consider the following configuration: scalable voltage output 2 is configured to respond to any note on messages received on MIDI channel 1. Connecting a MIDI keyboard, generating messages on MIDI channel 1, will cause the controller to generate a voltage which is proportional to the note number pressed on the key. The output can be configured to generate a voltage that is indirectly proportional to the MIDI message data byte.

## **Digital Voltage Output**

The digital voltage output generates a voltage of either 0 or +5V, depending upon the input MIDI message and configuration. The outputs behave as the scalable voltage outputs with the exception that MIDI data byte value of less than 64 constitutes an off state and values greater than 63 constitute an on value. Consider the following configuration: digital voltage output 1 is configured to respond to MIDI controller 80 messages on MIDI channel 1. If a controller 80 message on MIDI channel 1 with a controller value ranging from 0 to 127 is input, the controller will generate 0 volt output until the MIDI message controller value is greater than 63, at which point the voltage output would become +5V. The output can be configured to generate a voltage that is indirectly proportional to the MIDI message data byte.

## **MIDI Merge**

The controller will merge incoming MIDI messages with those generated by the controller. Incoming MIDI messages take a higher priority than those generated by the control voltage inputs. If an extremely intense stream of MIDI messages are input to the controller and the merge is enabled, the controller may respond sluggishly to the control voltages. This can be overcome by disabling the merge feature, using a dedicated MIDI merge box, or reducing the amount of input MIDI data.

## **Connectors**

The connectors on the Midi Controller are as follows:

Control voltage input, control voltage output, MIDI in, MIDI through, MIDI out 1, MIDI out 2, and Power. The connectors are DIN41612 sockets (pins spaced 2.54mm or 0.1” apart), which enables direct connection of third party sensors -- such as I-Cube sensors from Infusion Systems (<http://www.infusionsystems.com>). Male plugs are also provided in order to allow a user to create a permanent interface loom to a multiple sensor arrangement. This enables the performer to use a single plug connection during a performance setup to connect all the sensor inputs to the MIDI controller instead of

thirty-two individual connections. The same applies to the output control voltage connector.

### Control Voltage Input

The control voltage input socket contains thirty-two columns and three rows. The top row is the +5V supply, the middle row is the control voltage input, and the bottom row is the 0V supply or digital switch return. The left-most 16 columns of the plug are the scalable control voltage inputs while the right-most 16 are the digital switch inputs.

Sensors can be created quite easily for use as a control voltage input. The MIDI controller provides a 0 and +5V for use as power sources for sensors (see figure below).

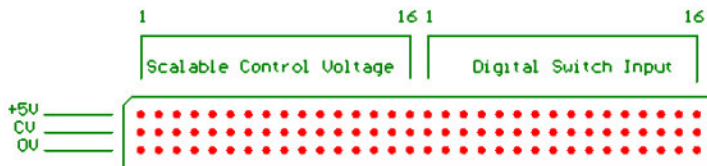

A simple sensor can be created by connecting the outer pins of a potentiometer to the sensor supply and the wiper pin to the sensor input. The digital switch sensors are effected by shorting the centre pin to the bottom pin. The picture below shows a potentiometer connected to scalable control voltage input 1 and a switch on digital switch input 16.

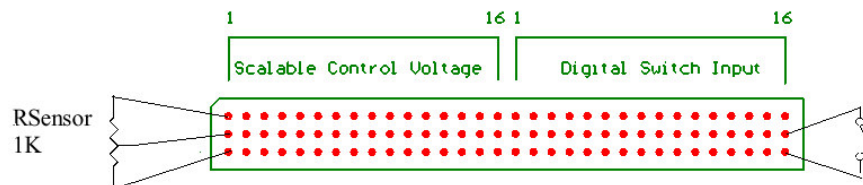

### Control Voltage Output

The control voltage outputs are used to provide control voltages through a 64-way (32x2) socket. The top row provides the positive voltage with the bottom row providing a common voltage return – i.e. the pins on the bottom row are all shorted together. The first eight columns are the scalable 10V outputs, the next eight are not used, the next eight are the digital 5V outputs, while the last eight are not used (see below).



The outputs can supply approximately 30 to 40 mA per channel, and as such are only suitable for low power situations. Using the voltage return as a reference for an external circuit can however, allow the voltage to control higher power devices. Eight-bit resolution is possible for the outputs using two MIDI messages or pitch bend.

Consider the following circuit:

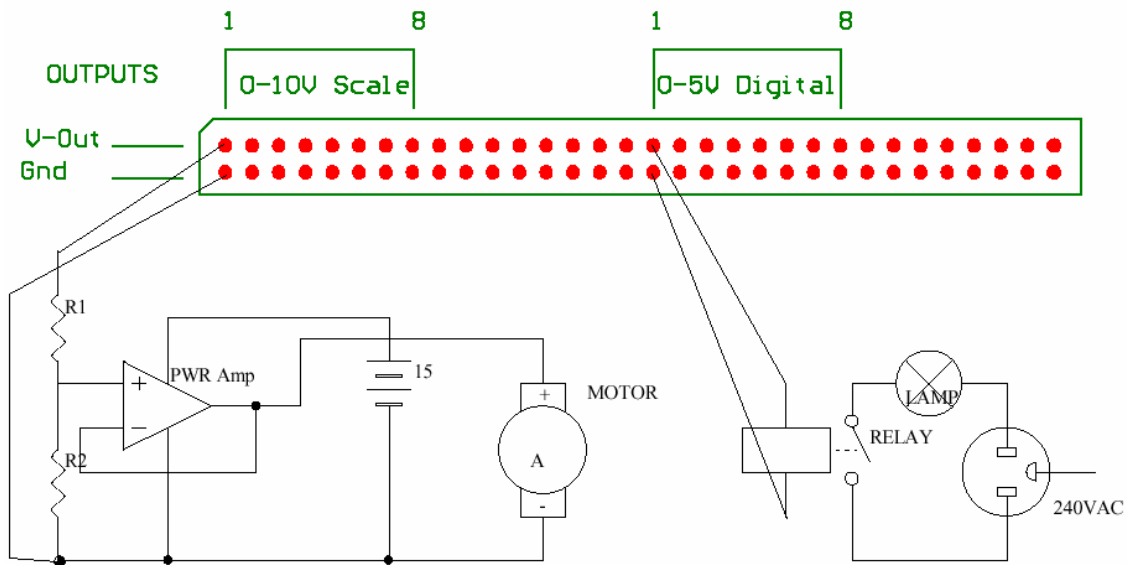

Scalable output voltage 1 is used to control the speed of a high current motor that has its own power source (note that the negative of the battery is connected to the voltage reference of the voltage output). Additionally, digital output 1 controls a relay that switches a 240V lamp on and off.

### Configuration

The MIDI controller comes with the following factory default configuration:

- MIDI merge enabled
- Scalable CV inputs 1 to 16 – Controller numbers 12 to 27 on MIDI channel 1 through MIDI output 1. Controller value 0 to 127 proportional to input control voltage.
- Digital switch inputs 1 to 16 – Controller numbers 64 to 79 on MIDI channel 1 through MIDI output 1. Controller value equals 0 and 127 for switch open and closed respectively.
- Scalable CV outputs 1 to 8 – the controller value for controller numbers 1, 2, 4, and 7 on MIDI channels 1 and 2 set the output voltage. The following table maps MIDI controller number and channel to CV output:

MIDI channel	MIDI controller number	CV output number
1	1	1
1	2	2
1	4	3
1	7	4
2	1	5
2	2	6
2	4	7
2	7	8

CV output voltage ranges from 0 to approximately +10VDC with controller value 0 to 127 respectively.

- Digital CV outputs 1 to 8 – controller numbers 80 to 95 on MIDI channel 1 set the voltage output to 0V for controller values 0 to 63, while controller values 63 to 127 set output to +5VDC.

The following configuration options (default off) are available for each individual channel:

- Mute – cause the input or output to have no effect.
- Invert – reverses the effect of the controlling data byte.
- Data 1 varies:
  - (a) Control Voltage input- causes a control voltage input to generate the data 1 value of the MIDI message proportional (or inversely proportional depending upon Invert value), with the data 2 value (if applicable to message type) at the configured value. See section on Scalable Voltage Input for an example.
  - (b) Control voltage output – causes the MIDI controller to generate a control voltage whose value is dependent upon the value of the data 1 byte of the MIDI message. See section on Scalable Voltage Output for an example.
- MIDI output 2 – causes input control voltage to generate a MIDI message on MIDI output 2 instead of MIDI output 1.

- **Generate on reset** – causes the MIDI controller to generate a MIDI message or control voltage when the device first starts or is reset, to the value configured. This feature is useful for setting default values in a performance. For example, if control voltage 1 was configured to control the panning (controller 10) on channel 1, but the initial pan required on this channel was dead centre (value 63), the MIDI controller can be configured to generate a controller 10 message on MIDI channel 1 with a controller value of 63. Alternatively, if a control voltage output should be +3V at the start of a performance, the CV output could be configured to generate this voltage when the unit starts up.
- **Use two messages**—causes CV input and output to be transmitted over two separate MIDI messages.
- **Scale Input**—Scales the CV input to produce MIDI messages only between certain ranges. Available only for CV inputs.